

Brake Caliper DH 012 FEM

spring activated – electromagnetically released

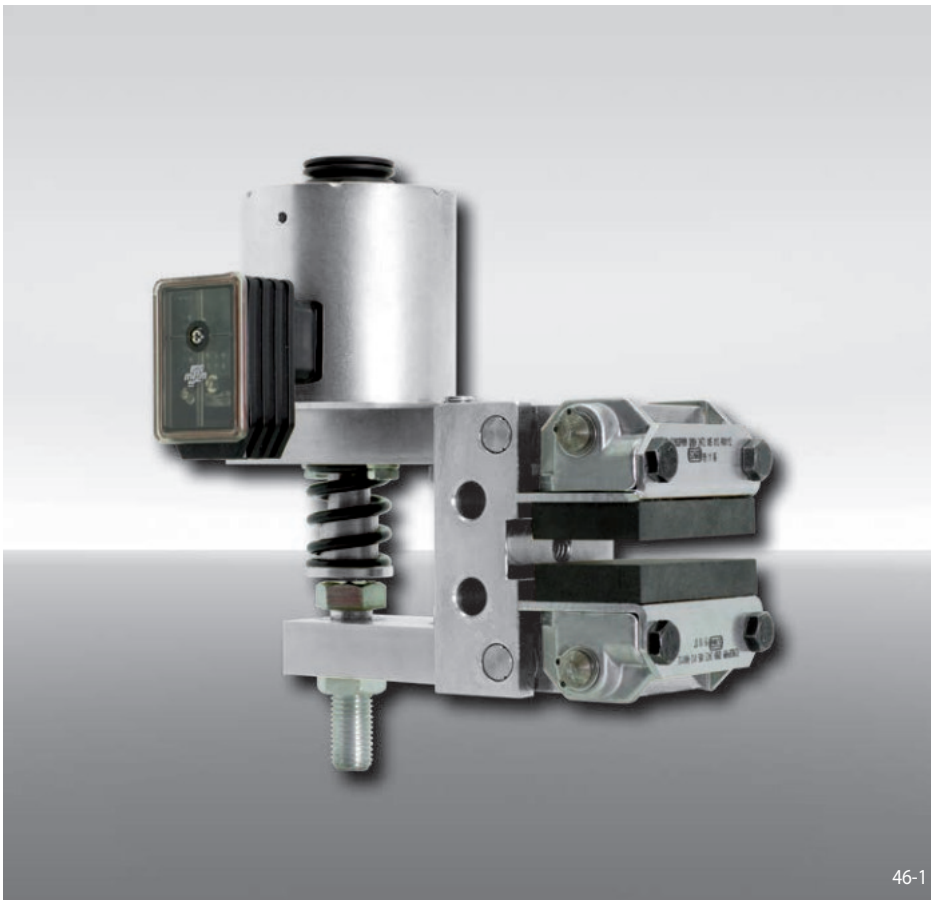

46-1

Features

Features	Code
Brake Caliper	D
Mounting to the machine at right angles to the brake disc	H
Frame size 012	012
Spring activated	F
Electromagnetically released	E
Manual adjustment to accommodate friction block wear	M
Electromagnet for 110 V	410
Electromagnet for 230 V	420
Thruster mounted right or left available	R L
Thickness of brake disc 12,5 mm	12

Example for ordering

Brake Caliper DH 012 FEM, electromagnet for 110 V, thruster mounted right, thickness of brake disc 12,5 mm:

DH 012 FEM - 410 R - 12

Technical Data

	Brake Caliper DH 012 FEM	
	with electro-magnet 410 for 110 V	with electro-magnet 420 for 230 V
Brake disc diameter	Braking torque	
mm	Nm	
200	94	
250	130	
300	160	
355	200	
430	250	
520	310	
Clamping force	1650 N	
Power consumption in open position	12 W (100% duty factor)	
Fuse rating	6A	
Max. number of actuation	600/h permanent activations at 20° C ambient temperature	
Weight	7 kg	

The braking torques shown in the table are based on a theoretical friction coefficient of 0,4.

Accessories

Universal Transformer see page 166.

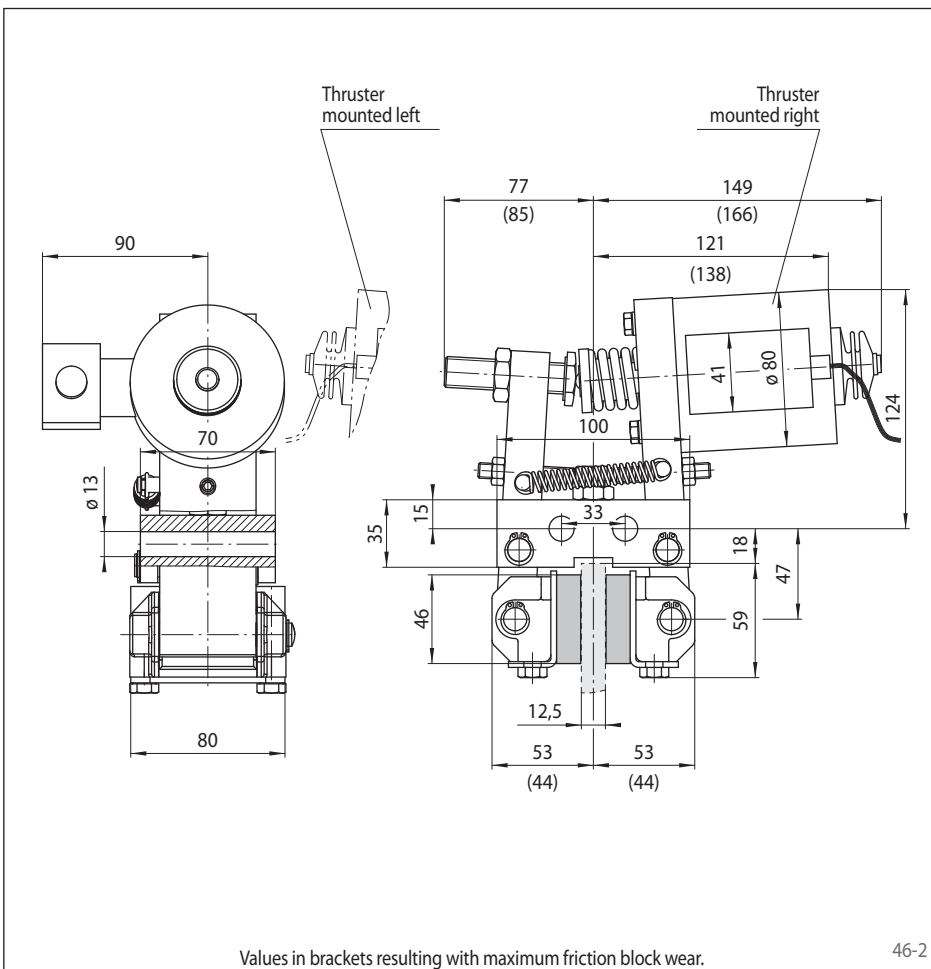

Values in brackets resulting with maximum friction block wear.

46-2

Morskate®



Any questions? Please contact us.

Morskate Aandrijvingen BV

Oosterveldsingel 47A
7558 PJ Hengelo (Ov)
The Netherlands

NL

T +31 (0)74 - 760 11 11
info@morskateaandrijvingen.nl
www.morskateaandrijvingen.nl

DE

T +49 692 - 222 34 95
info@morskateantriebstechnik.de
www.morskateantriebstechnik.de

EN

T +31 (0)74 - 760 11 11
info@morskatedrivetechnology.com
www.morskatedrivetechnology.com